

1. Position the gate in the centre of the gap, ensuring that it is perfectly upright.
2. Adjust the left and right handwheels evenly until the gate is fixed in position with the wall cups (3) held in place.
3. Mark the position of the four wall cups and remove the gate.
4. Following the correct fitting method as detailed in the chart opposite, stick or screw the wall cups to their marked positions using the adhesive pads (4) or screws (5) or provided, together with appropriate wall plugs or fixing aids.
5. Reposition the gate with the outside bars an equal distance from each side of the gap. Locate the spindles into the wall cups. Turn the bottom handwheels until they both just touch the gate frame. Then tighten them until secure.
6. Turn the top handwheels until they touch the gate frame. Tighten both handwheels to an equal number of turns (Note that the handwheels will jolt with every turn, until there is a 1 to 2mm gap between the handle and the frame (ensure it is no more than 1 to 2mm). Finally give the handwheel a further turn from the gate door. The gate is now ready for use.
7. Remove the securing tie from the gate door. The gate is now ready for use.

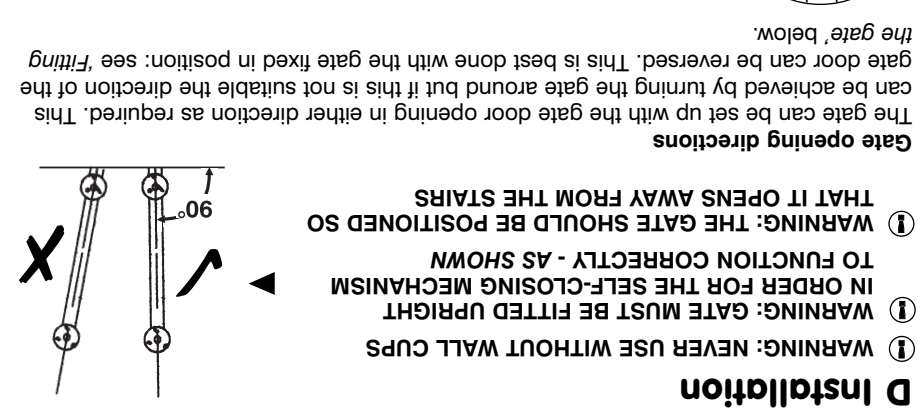
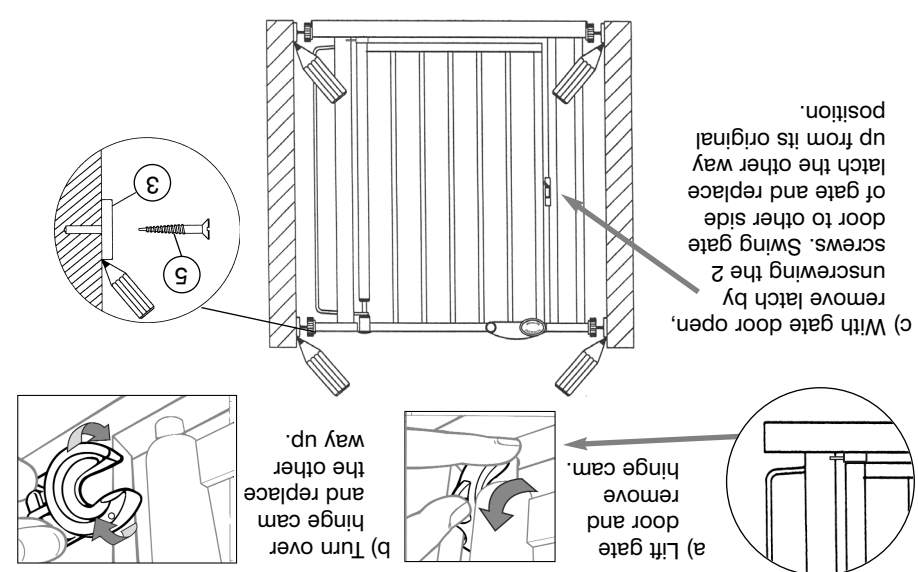

E Using the gate

Before using the gate ensure that it is fitted correctly and is secure.

Opening the gate
Slide and hold back the release button on the handle and lift the door. Whilst maintaining the lifting action the gate door can be opened.

Closing the gate
Once opened the gate door will close and lock automatically. Do not push or slam the gate door shut. Always make sure the gate door is shut and locked fully before leaving unattended.
The gate can be shut manually by holding the handle and closing the gate door until it locks into position.

Audible Locking Indicator: When the door closes and locks there is a distinct audible 'click' sound. This sound indicates the door is properly closed and locked. If you do not hear this sound the door has not closed correctly. If this occurs follow the advice given in the Maintenance section of the instructions or call the Customer Care Line.

Removing the gate
This gate is fitted with tamper proof handwheels. The top two handwheels can only be slackened whilst the gate is in the open position and the pressure released by pulling the side bars away from the wall cups.

F Maintenance

Check the gate periodically to ensure that the wall surface, wall cups, spindles, handwheels and locking devices are all functioning correctly. Additional and replacement parts can be obtained by contacting the Bettacare Customer Service Department via the Careline. If the gate begins to swing shut more slowly than before, the lower hinge may need cleaning. With the gate in place, lift the gate door fully, remove the hinge cam and clean both the cam and the hinge rod with a damp cloth. Replace the hinge cam, ensuring that it is the correct way round for the gate opening and release the gate door gently back into the locked position.

G Extensions

Gate extensions are available in 4 sizes - 7.2cm, 14.4cm, 36cm and 79.3cm. Extensions can be used to extend the gate up to a maximum of 155cm.

'Y' Spindles are available for fitting gate to rounded newel posts etc.

Extensions and 'Y' Spindles can be obtained from your stockist or from the Bettacare website.

Caution: Do not extend to more than 155cm.

Customer Care Line: 01293 851896

Bettacare Ltd
9-10 Faygate Business Centre, Faygate, West Sussex, RH12 4DN
Tel: +44 (0)1293 851896 Fax: +44 (0)1293 851065
Email: info@bettacare.co.uk Website: www.bettacare.co.uk

SUITABLE SURFACES		THIS GATE OFFERS THE FOLLOWING FIXING OPTIONS:	
✓	✓	✓	WITH ADHESIVE WALL CUPS
✓	✓	✓	LOW PRESSURE MOUNTING WITH SCREWED WALL CUPS
✓	✓	✓	LOW PRESSURE MOUNTING WITH SCREWED WALL CUPS
✓	✓	✓	RIGIDLY SUPPORTED WOODEN SURFACE (eg. DOOR FRAME/SKIRTING BOARD)
✓	✓	✓	UNSUPPORTED WOODEN SURFACE (eg. STAIR/NEWEL POST)
✓	✓	✓	PLASTERED SURFACE
✓	✓	✓	PLASTER BOARD STUD WALL - WOODEN SUPPORTING BATTEN RECOMMENDED
✓	✓	✓	WALLPAPERED SURFACE
✓	✓	✓	METAL SURFACE (eg. ALUMINIUM/STEEL DOOR FRAME)
✓	✓	✓	PLASTIC SURFACE (eg. UPVC DOOR FRAME)
✓	✓	✓	CERAMIC TILED SURFACE

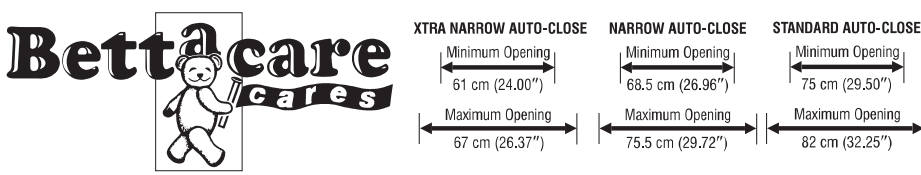
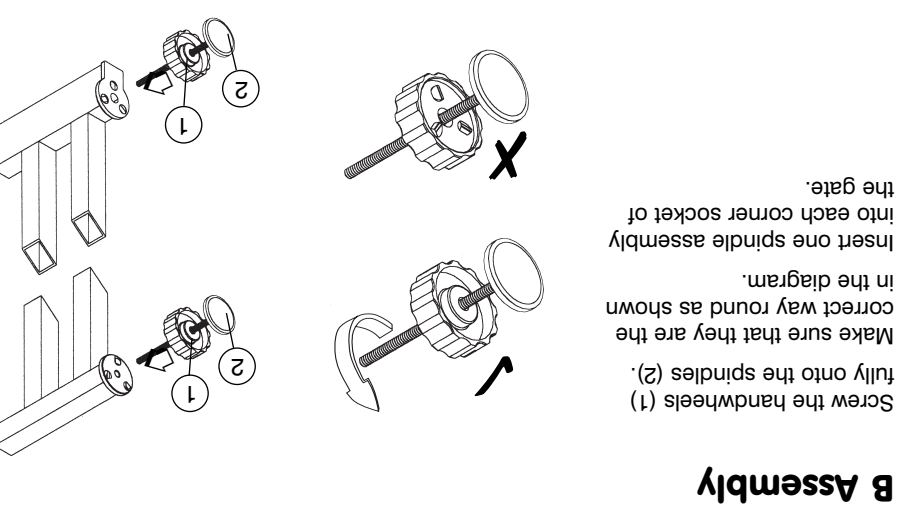
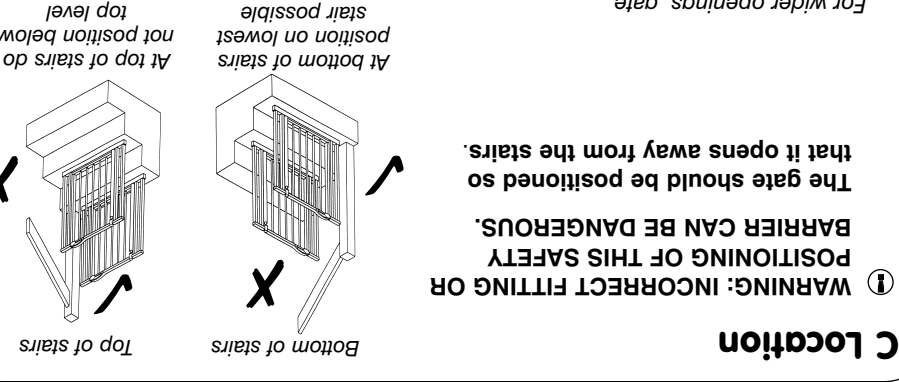

The Bettacare Auto-Close Gate

Fitting Instructions

IMPORTANT KEEP FOR FUTURE REFERENCE

Please read carefully before fitting

WARNING: Incorrect fitting or positioning of this safety barrier can be dangerous.
WARNING: Do not use the safety barrier if any components are damaged or missing.
WARNING: The safety barrier must not be fitted across windows
WARNING: Stop using the barrier if the child is capable of climbing it.

This gate conforms to EN1930.2000 inc A1.2005 when fitted as instructed.
This gate is designed for children up to the age of 24 months.
Be aware of the danger of older children climbing over the barrier.
For use as a barrier for doorways and stairs.
Check that the fixing surface is suitable for the purpose and structurally sound.

A Contents

