

AU-LUCCA

Wall Shelf Instructions

LUC4125: 4A,4B,4C,4D,4K

IMPORTANT: RETAIN FOR FUTURE REFERENCE.
READ CAREFULLY.

CH230: AUS

4K

10 min.

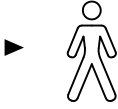

4D

4C(R)

4A

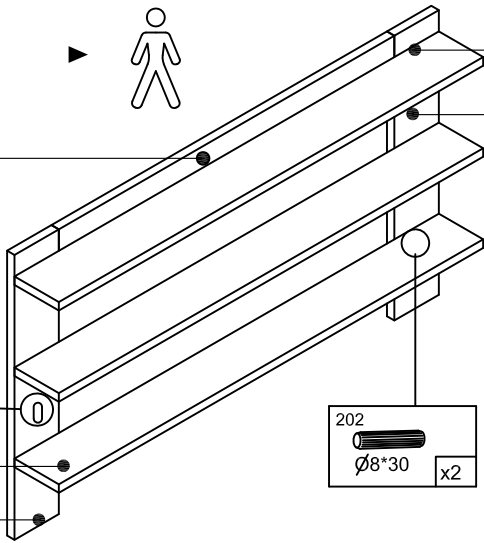

4B(x2)
4C(L)

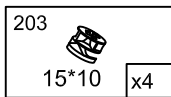
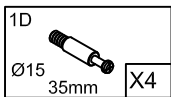
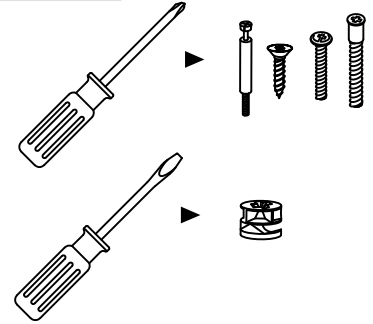
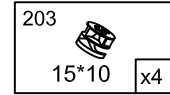
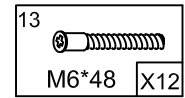
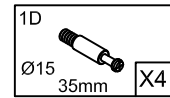

4A
4C(L)
4C(R)

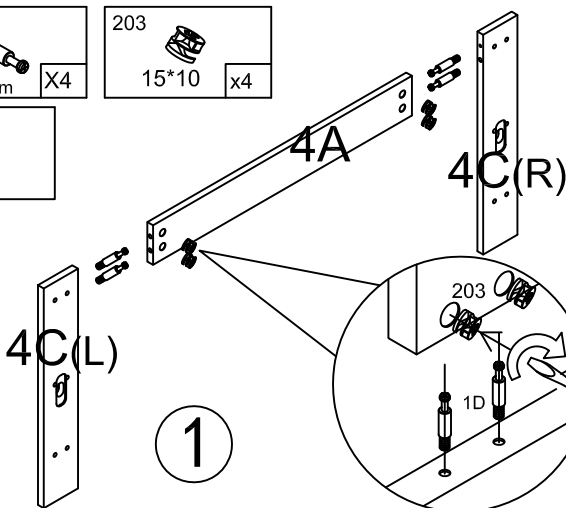

1

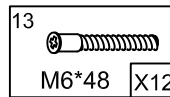

4B
4D

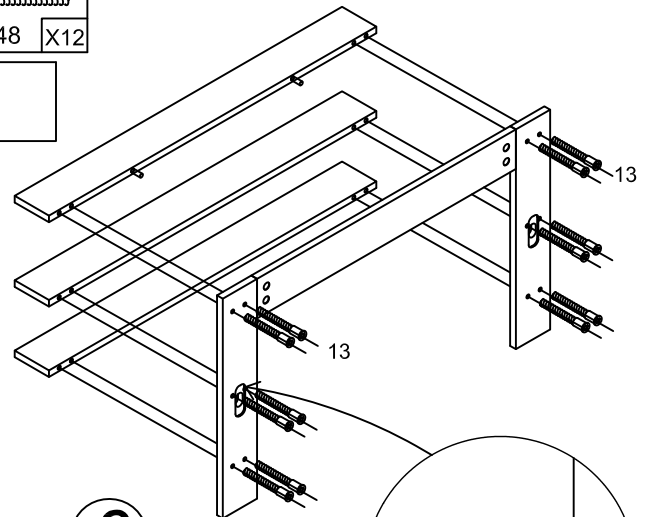

2

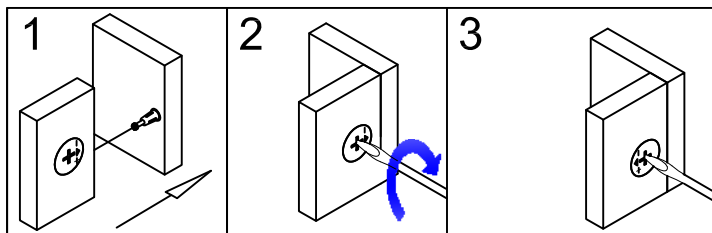

3

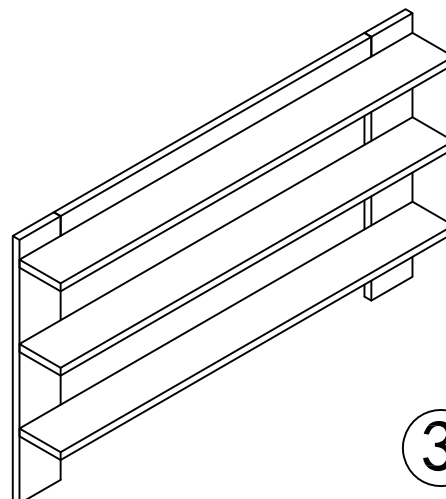

LOVE N CARE WARRANTY AGAINST DEFECTS

All Love N Care products are guaranteed for twelve months from the date of purchase. Our goods come with guarantees that cannot be excluded under the Australian Consumer Law. You are entitled to a replacement or refund for a major failure and for compensation for any other reasonably foreseeable loss or damage. you are also entitled to have the goods repaired or replaced if the goods fail to be of acceptable quality and the failure does not amount to a major failure. This covers against faults which develop through faulty materials and workmanship. Misuse, accidental damages, normal wear and tear or neglect are not covered. If a fault becomes apparent, please return the item to the store of purchase with your receipt. You must inform the store what the defect is. We will then arrange for its repair or it will be assessed for replacement as expediently as possible. The benefits of this warranty are in addition to other right and remedies under the law in relation to the goods or services to which this warranty relates. If you are unable to return the item to the store of purchase, you can contact Love N Care on free call 1300 732 599.

Where you send the product directly to the manufacturer then you may be liable for the costs of transportation to and from Love N Care. Love N Care will meet the reasonable expenses incurred by a consumer in a making a warranty claim. You can claim expenses incurred in making a claim by contacting our customer service team on 1300 732 599 or by email at info@lovencare.com.au

Care and Maintenance

All love N Care products have one year warranty from the date of purchase. It is recommended to regularly inspect and maintain movement of locking devices and security of essential components. Regularly check all parts for wear and tear. Your furniture may be cleaned by wiping with a damp cloth and drying with a soft clean cloth. Do not use abrasives, bleach, alcohol or ammonia-based household polishes. Take care when handling or moving the furniture. Careless handling may cause damage. Check the cot screws and locks to make sure they are all kept in good working order. If any of the parts are missing or broken you should contact the manufacturer and discontinue using the cot until they are replaced.